

SPL 9000

Automotive lift date: 07/2000

Manual date: 07/2000

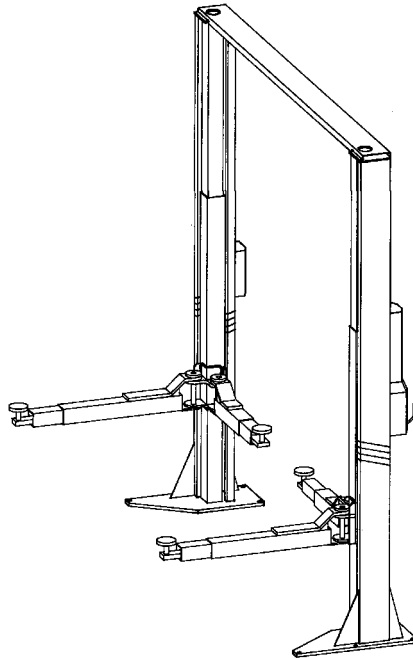

Operating instruction and documentation

serial-number:.....

retailer address / phone

Nussbaum
HEBETECHNIK

Nussbaum Hebetchnik GmbH & Co. KG || Korker Straße 24 || D-77694 Kehl-Bodersweier ||
Tel: +49 (0) 78 53/89 90 || Fax +49 (0) 78 53/87 87 ||
E-mail: nussbaum.lifts@t-online.de || <http://www.nussbaum-lifts.de> ||

Table of contents

Record of Installation.....	3
Record of handing over.....	4
1. Introduction.....	5
2. Master Document of the automotive lift.....	6
CE-certificate/attestation of conformity.....	7
3. Technical Information.....	8
Data Sheet over floor.....	9
Foundation plan	10
Electrical diagram drawing (standard version).....	11
Electrical clamped connection drawing.....	12
Electrical diagram drawing (single phase Canada version).....	13
Electrical diagram drawing (three phase Canada version).....	14
Electrical diagram drawing (single phase USA version).....	15
Hydraulic diagram drawing.....	16
4. Safety regulations.....	17
5. Operating instructions.....	17
6. Troubleshooting.....	19
Emergency lowering.....	20
Torn rope.....	21
7. Maintenance.....	22
8. Security check.....	22
9. Installation and Initiation.....	23
Installation of the lift.....	23
Regulations for installation.....	23
Erection and doweling of the lift.....	23
Initiation.....	26
Changing of the installation place.....	26

Appendix

Document "First security check before Installation"
Document "Regular security check"
Document "Extraordinary security check"
Spare parts list

Record of handing over

The automotive lift SPL 9000 with the

serial number.: was installed on

at the firm..... at.....

the safety was checked and the lift was startet.

The persons below were introduced after the installation of the automotive lift. The introduction was carried out from an erector of the lift-manufacturer or from a franchised dealer (competent).

.....
date	name	signature

.....
date	name	signature

.....
date	name	signature

.....
date	name	signature

.....
date	name	signature

.....
date	name of the competent	signature of the competent

1. Introduction

The document "**Operating Instructions and Documentation**" contains important information about installation, running and preserving of the automotive lift.

To furnish proof of **installation of the automotive lift** the form "Record of Installation" must be sent undersigned to the manufacturer.

To furnish proof of the single, regular and special security checks this documentation contains forms. The forms should be used to document the checks. They should also be left in this documentation.

Every **Changes in the construction** and **changing place** of the automotive lift must be registered in the "Master document" of the lift.

Installation and check of the automotive lift

Only specialist staff is allowed to do the works concerning safety and to hold the safety checks of the lift. They are called experts and competents in this document.

Experts are persons (for example self-employed engineers, TÜV-experts) which have got an instruction and experience to check and to test automotive lifts in an expert's report. They know the signified regulations for protection of labour and prevention of accidents.

Competents are persons which have got enough knowledge and experience with automotive lifts. They took part in a training from the lift-manufacturer (servicing erectors of the manufacturer and the franchised dealer are Competents)

Information of danger

To show danger and to show important information the three symbols below with the special meanings are used. Pay attention of those passages, which are marked with these symbols

Danger!
 ***This sign marks a danger to life. Inexpert handling of the marked series of event ist dangerous to life***

Caution!
 ***This sign marks a caution against possible damage of the automotive lift or other material defects in case of inexpert handling .***

Indication!
 ***This sign marks an indication for an important function or for another important note.***

CE-certificate/attestation of conformity

The automotive lift SPL 9000 with the serial number
is in accordance with the tested lift (CE-certificate-number 04 205-2740/98)

.....
place, date

.....
company stamp, signature

ZERTIFIKAT
CERTIFICATE

RWTÜV

Registrier-Nr./Registered No.:
04 205-2740/98

EG-Baumusterprüfbescheinigung gemäß Anhang VI der EG-Richtlinie 98/37/EG
EC-type approval according to annex VI of the EC-Directive 98/37/EC

Zeichen des Auftraggebers Reference of applicant	Auftragsdatum Date of application	Aktenzeichen File reference	Prüfbericht Nr. Test report No.	Ausstellungsdatum Date of issue	Gültigkeit bis Expiry date
Hr. Müller	06.10.1998	3.1.1-1082/98	2738/98 u. 2739/98	02.05.2000	02.05.2005

Hiermit wird bestätigt, daß das nachfolgend genannte Produkt den grundlegenden Anforderungen der Richtlinie des Rates vom 22.06.98 zur Angleichung der Rechts- und Verwaltungsvorschriften der Mitgliedstaaten über Maschinen entspricht.
We hereby certify that the product mentioned below meets the basic requirements of the council directive dated 22.06.98 on the approximation of the laws, regulations and administrative provisions of the member states relating to machinery.

CE 0044

Antragsteller
Applicant: Otto Nußbaum GmbH
Korker Straße 24, D-77694 Kehl

Fertigungsstätte:
Manufacturing plant: s.o.

Produktbeschreibung:
Product description: Kfz.- Hebebühne (Vehicle lift): Typ 2.40 SPL
Nennlast (Nominal load): 4000 kg

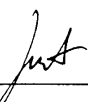
Zertifizierungsstelle des RWTÜV e.V.
für Gerätesicherheit, Aufzüge
und Medizintechnik, notifiziert bei der
EG-Kommission unter Nr. 0044

Rheinisch-Westfälischer
Technischer Überwachungs-
Verein e.V., Sitz: Essen
Langemarckstraße 20
D-45141 Essen
Postfach 10 32 61
D-45032 Essen
Telephone +49/201 8 25-0
Telefax +49/201 8 25-33 56

3. Technical Information

Technical ratings

Lifting capacity:	9000 pounds = 4077 kg
Load sharing:	max. 2:1 in or against drive-on direction
Lifting time:	ca. 32 sec
Lowering time:	ca. 41 sec
lifting capacity:	1740 mm
Line voltage:	3 x 400V, 50 Hz (standard) <u>(observe the power supply of your state)</u>
Driving voltage:	220 V
Power rating:	3.0 kW (standard)
Motor speed:	2800 revolution/minute
Output oil-pump:	3 ccm/revolution
Hydraulic pressure:	185 bar
Responsing pressure of pressure relief valve:	215 bar
Hold-up oil tank:	ca. 8 Liter
Sound level (measured at operating panel)	75 dBA

Safety devices

1. Ratchets
safety device of the load against unintentional lowering when the hydraulic system isn't tight any more
2. Screens at hydraulic cylinder
safety device for slow lowering in case of pipe breaking
3. Lockable main switch
safety device against unauthorized using

Data sheet

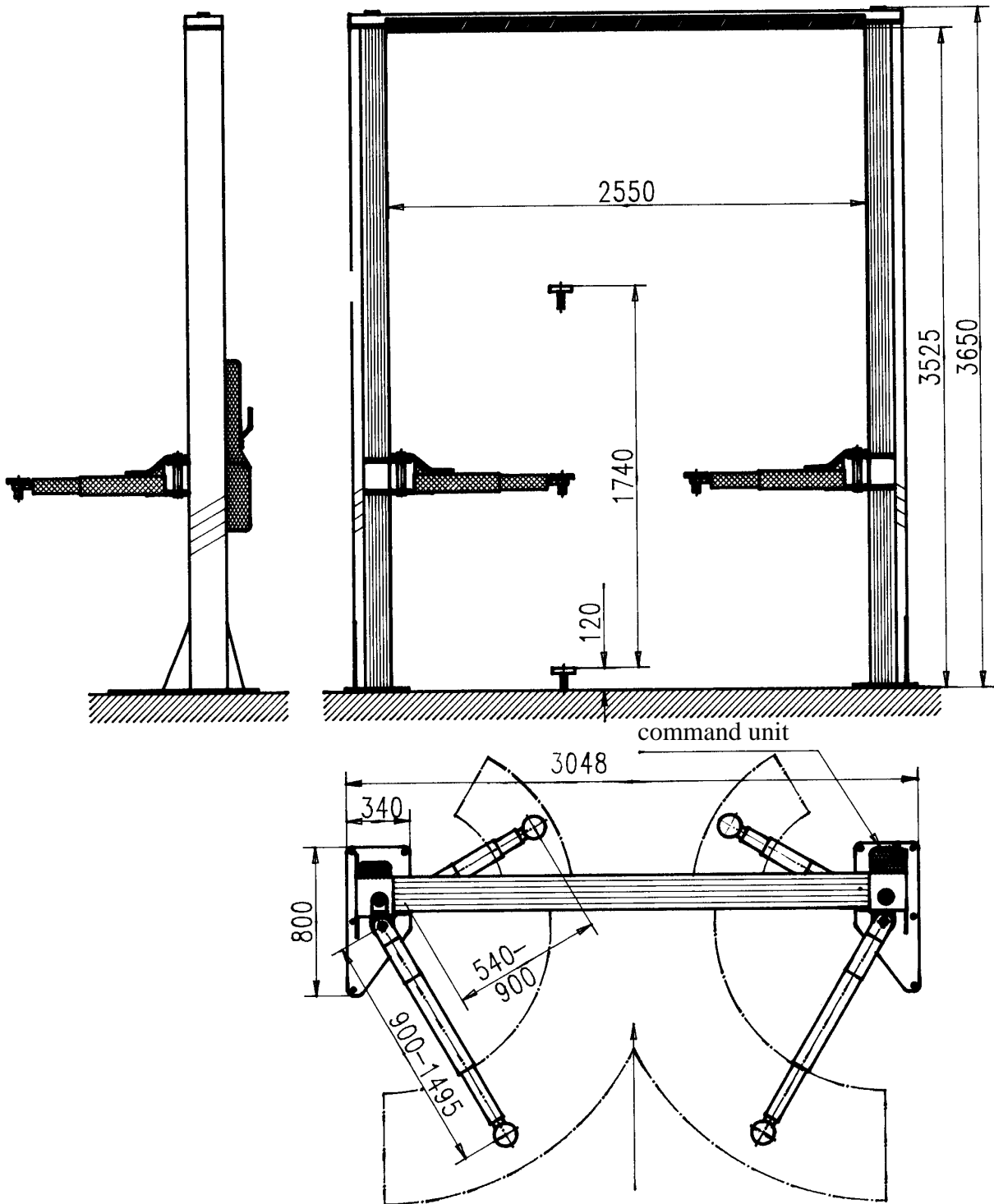

Foundation plan

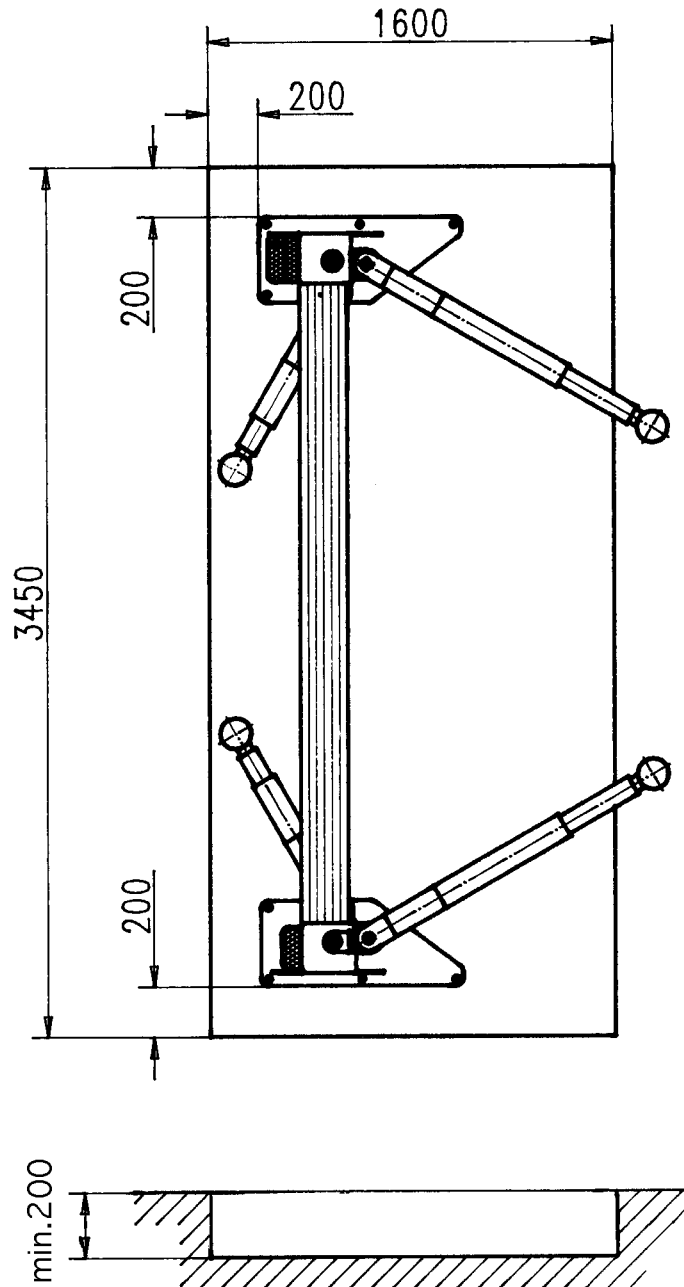

Quality of the concrete B25

Electrical diagram drawing (standard version)

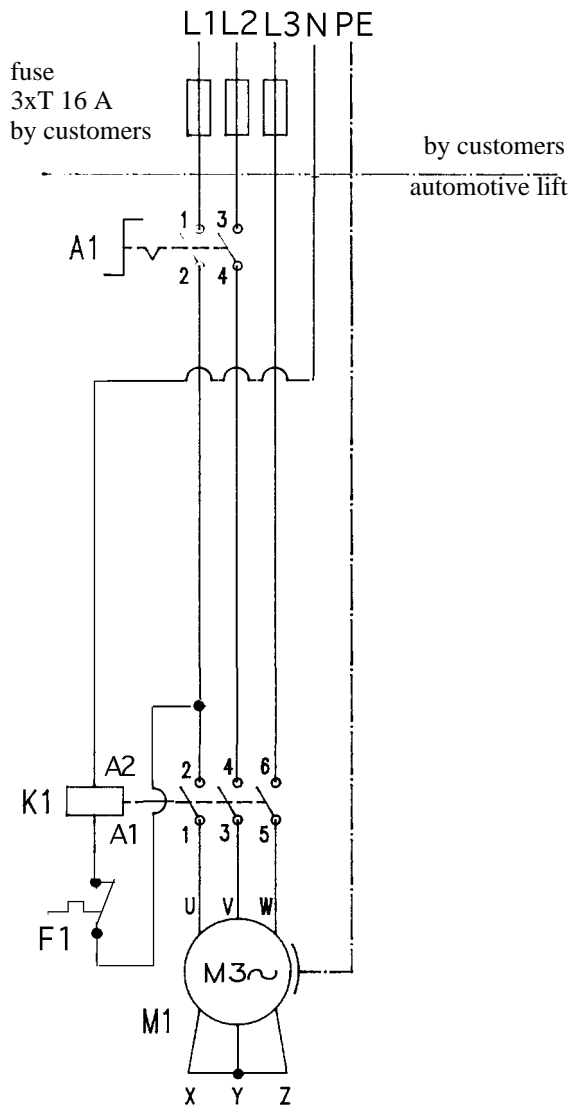

Parts list for electrical diagram

- A1: reversing switch for lifting
- M1: motor 3,0 kW
- F1: thermofuse in motor
- K1: up contactor

- A1, A2: clamped connections
- 1-6: clamped connections
- U;V;W: clamped connections

Clamped connection drawing

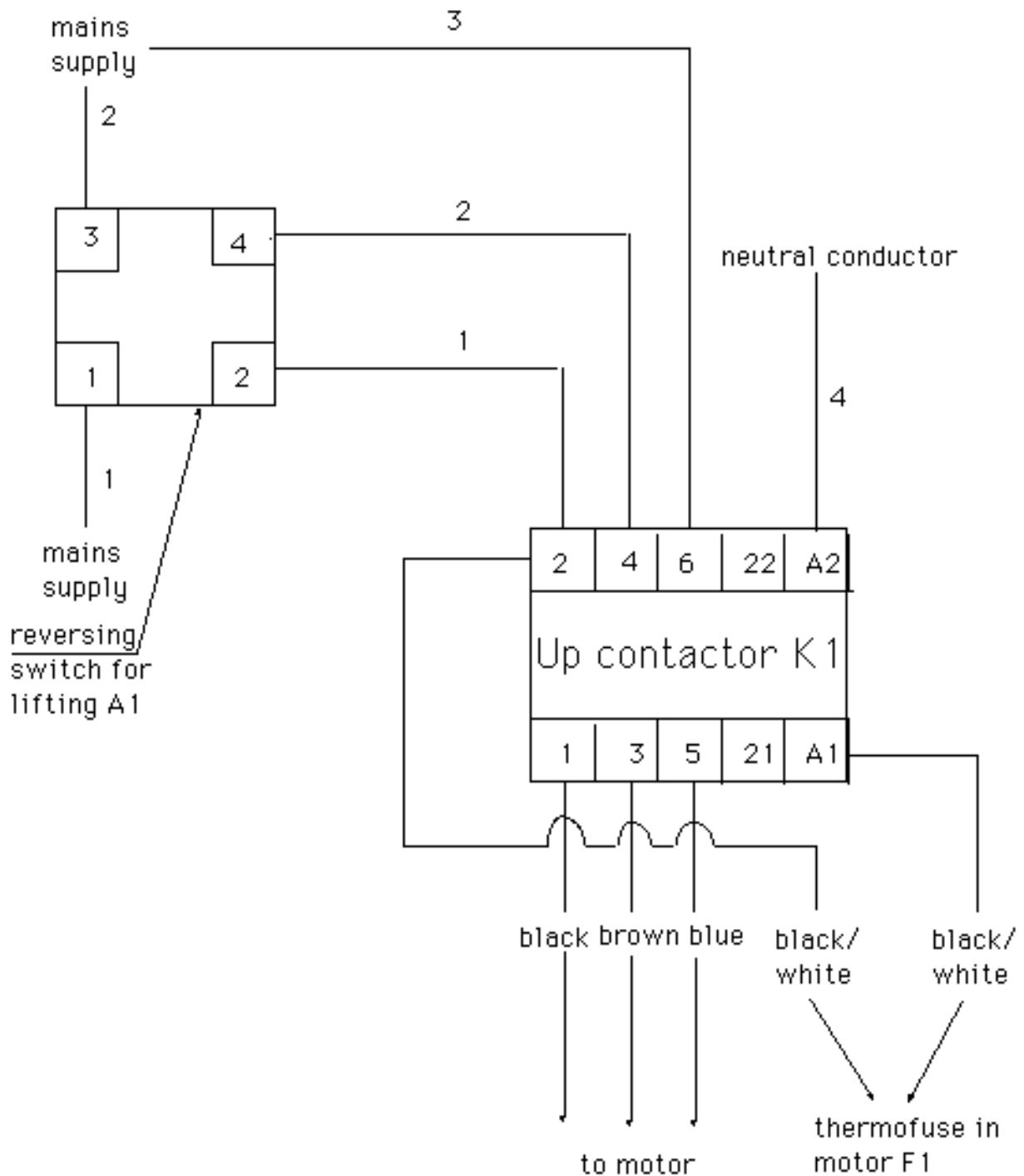

Electrical diagram drawing (single phase Canada version)

ATTENTION ELECTRICIAN:
CONNECT POWER SUPPLY
TO CONTACTOR TERMINALS
L1 - L2

WIRING DIAGRAM

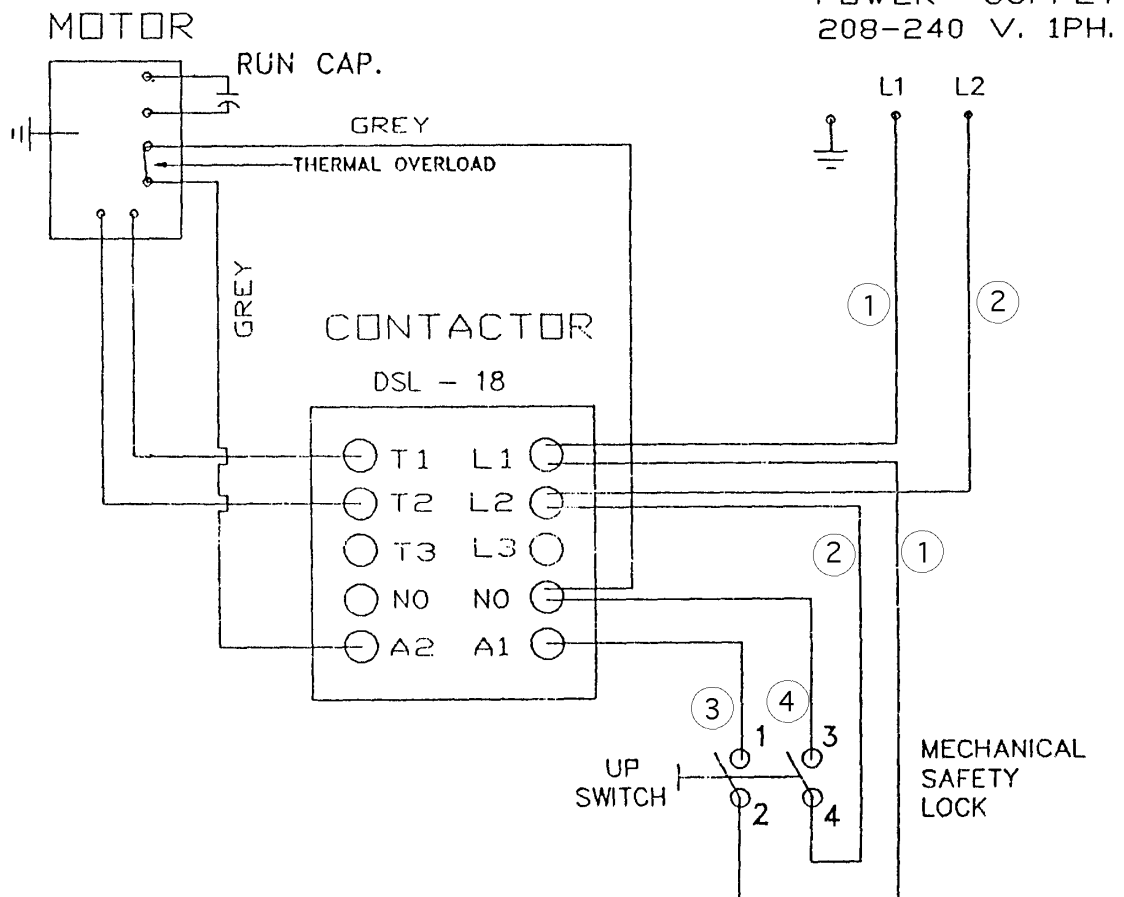

Electrical diagram drawing (Canada version 3 Phase)

ATTENTION ELECTRICIAN:
CONNECT POWER SUPPLY
TO CONTACTOR TERMINALS
L1 L2 L3

WIRING DIAGRAM HBT-8000

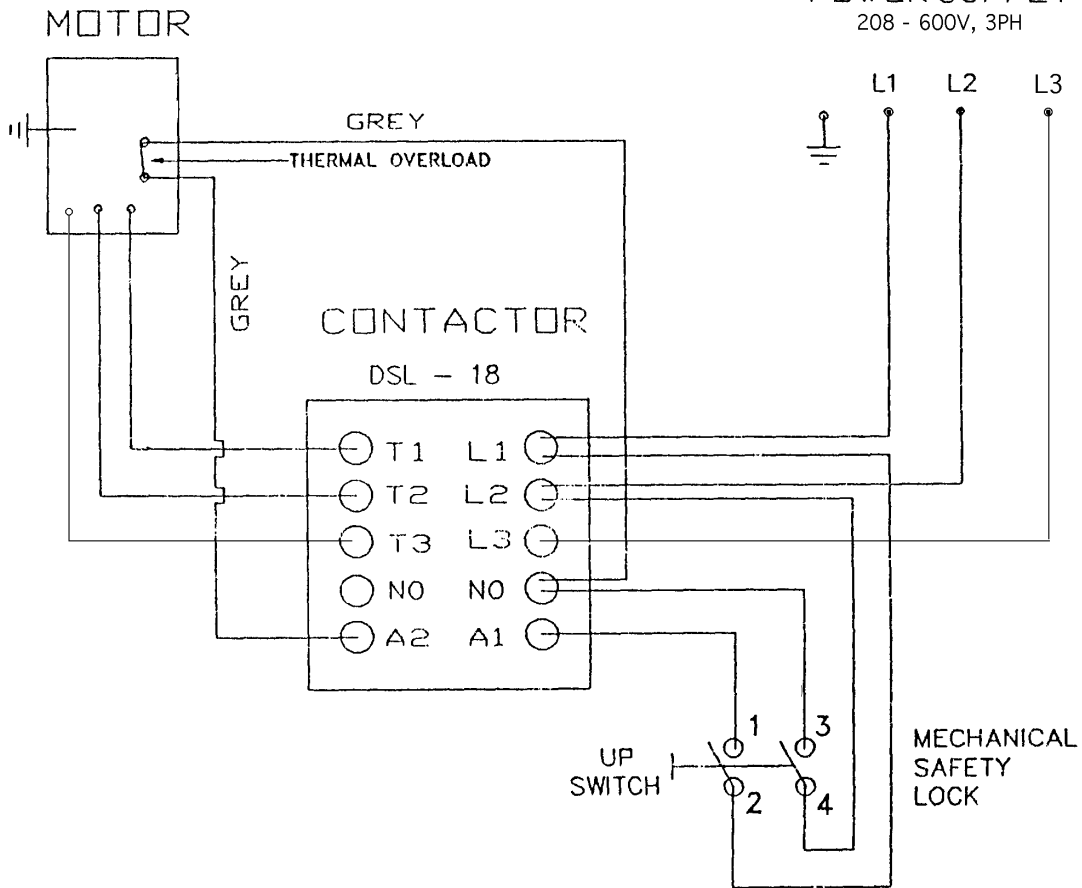

Electrical diagram drawing (single phase USA)

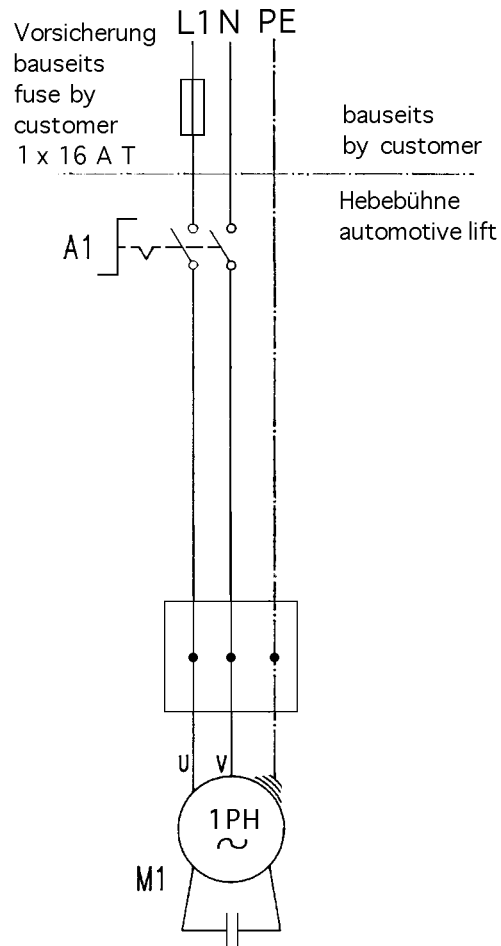

A1 main switch

M1 motor

Hydraulic diagram drawing

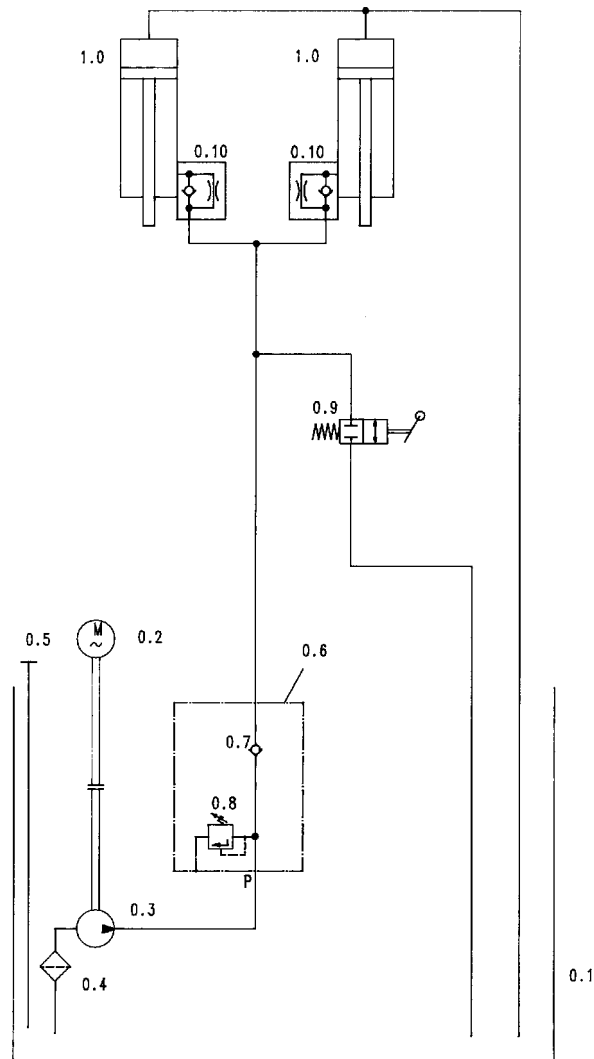

Parts list of hydraulic diagram

- 0.1: oil-tank
- 0.2: motor
- 0.3: pump
- 0.4: oil-filter
- 0.5: oil-level gage
- 0.6: hydraulic block complete
- 0.7: holding valve
- 0.8: pressure relief valve
- 0.9: ball valve (lowering)
- 0.10: flow control holding valve
- 1.0: hydraulic cylinder

4. Safety regulations

Using automotive lifts for working the regulations of accident prevention EN1493/Aug.98 (CEN/TC 98“automotive lifts“ “european regulation“) must be observed.

Especially the following regulations are very important

- The laden weight of the lifted vehicle mustn't be more than 9000 pounds = 4077 kg. The max. load sharing is 2:1 in or against drive-on direction.
- During working with the lift the operating instructions must be followed.
- Only trained personnel over the age of 18 years old are to operate this lift.
- During lifting or lowering the vehicle it must be observed from the operator.
- It's not allowed to stay under the lifted or lowered vehicle (except for the operator).
- It's not allowed to transport passengers on the lift or in the vehicle.
- It's not allowed to climb onto the lift during lifting or lowering or onto a lifted vehicle.
- The Automotive Lift must be checked from an expert after changes in construction or after repairing carrying pads.
- It's not allowed to start with operations at the lift before the main switch is switched off.
- Switching on or switching off the lift you have to take care that the lifting and lowering movement are steady.
- It's not allowed to install the standard-automotive lift in hazardous location.

5. Operating instructions



The Safety Regulations must be observed during working with the automotive lift. Read the safety regulations in chapter 4 carefully before working with the lift!

The operating elements are shown in picture 1.

Lifting the vehicle with the SPL 9000

- Drive vehicle between the two columns, longitudinal direction and transverse direction in centre.
- Safe the vehicle against rolling away, switch into gear, activate parking brake
- Slew carrying arms under vehicle and position pads at the points which are provided from the vehicle-manufacturer
- Control the dangerous places of the lift and be sure that there are no objects or people in the immediate area of the lift or on the lift
- Turn operating (reversing) switch to position " " and hold position " " until the wheels of the vehicle are free

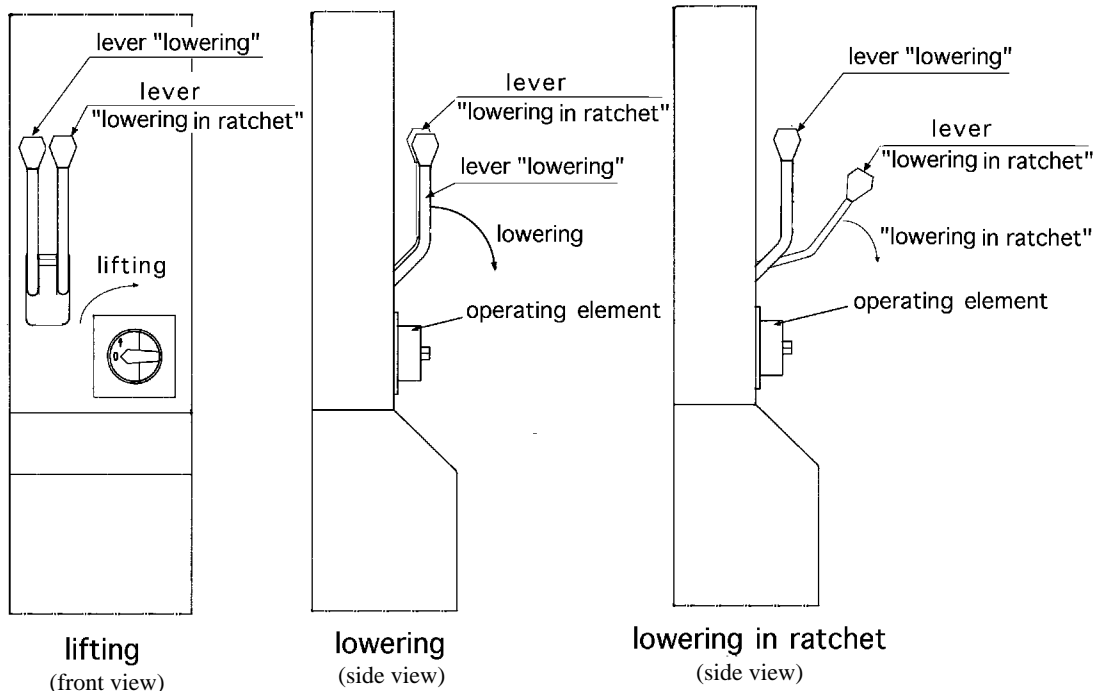

pic. 1: operating elements

- When the wheels have been lifted free, stop with lifting; let go of operating (reversing) switch and check safety sit of the pads under the vehicle.



The sit of the pads under the vehicle is very important. If the position of the pads isn't all right the vehicle might fall down!



Lifting great vehicles (transporter, cross country cars) pay attention that the roof doesn't touch the traverse of the lift. In case the vehicle touches the traverse of the lift, a switching off strip is pressed upside, which pulls the operating switch via rod assembly to position "0", so the lift doesn't lift any more. Afterwards the operating switch can not be turned to position " "any more. However the lift can still be lowered by pulling the operating lever (refer to "lowering of the lift"). After lowering the lift to the position where the switch off strip is free, the operating switch is released and the lift can be lifted again.

- Lift vehicle on height for working; turn operating switch to position " ", keep it until height for working or top position is reached



When the lift is lifted to top position the operating switch is pulled to position "0" with the help of a rod assembly. So lifting stops. Afterwards the operating switch can not be turned to position " "any more. The lift can only be lowered (as described in section "lowering of the lift"). When top position is left the operating switch is released and the lift can be lifted again.



In case the operating switch is not pulled to position "0" at top position automatically the ratchet -rope is slack or torn. Refer to chapter "Troubleshooting" section "torn rope"!

Lowering the vehicle with the automotive lift

- Control the dangerous places of the lift and be sure that there are no objects or people in the immediate area of the lift or on the lift
- Lower the vehicle at the height for working or until the carrying arms reach the lowest position; Pull operating lever "lowering" (= lever left side) until height for working or until lowest position.



Attention! while using lever "lowering", both levers ("lowering" and "lowering in ratchet" will be activated!)

- When the lift is in lowest position, slew carrying arms inside and drive vehicle out of the lift

Lowering the the automotive lift in ratchet

- Control the dangerous places of the lift and be sure that there are no objects or people in the immediate area of the lift or on the lift
- Lower the vehicle in ratchet; pull operating lever "lowering in ratchet" (= lever right side).



Attention! Before going on with "lowering", lift the lift first a little bit until the ratchet is not engaged any more, then go on with lowering!

6. Troubleshooting

If the lift does not work properly, the reason for this might be quite simple. Please check the lift for the potential reasons mentioned on the following pages. If the cause of trouble cannot be found, please call the technical service.



Repairs at the lift's security devices as well as repairs and examinations of the electrical fittings may only be performed by specialists.

Problem: Motor does not start, lift is neither lifting nor lowering!

- Potential causes of trouble:**
- Fuse is defective: replace fuse
 - Feed line is cut
 - Motor is overheated: let it cool down for app. 10 min.

Problem: Lift is not lifting!

- Potential causes of trouble:**
- Level of hydraulic oil is too low
 - In case of cold weather the hydraulic oil is too viscous
 - ball-valve defective or dirty
 - coupling between motor and pump is defective
 - oil-filter in tank is dirty
 - things (nuts, screws...) are in the columns and block the low lift platform truck
 - height limit switch is activated

Problem: lift cannot be lowered!

- Potential causes of trouble:**
- lift is driven onto an obstacle
 - equalisation ropes are too tight. Make sure that the ropes are fastened (refer to chapter "Installation and Initiation")
 - Ratchets are engaged: move the lift up before lowering.
 - In case of cold weather the hydraulic oil is too viscous
 - ratchet-rope is torn; (refer to emergency lowering)

Problem: lift lowers by itself until the ratchet is engaged

- Potential causes of trouble:**
- holding valve isn't tight or dirty
 - ball-valve is leak or dirty

Problem: lift is jerked while lowering

- Potential causes of trouble:**
- equalisation ropes are too tight, check course of the ropes (refer to "installation and initiation")
 - air is in oil circulation; deaerate (refer to "installation and initiation")

Problem: operating (reversing) switch is not pulled back

- mögliche Ursachen:**
- safety-rope is torn (refer to "torn-rope")
 - safety-rope is slack (refer to "torn-rope")

Emergency lowering

If the ratchet-rope is torn the lift can not be lowered any more because one or two ratchets are engaged. In this case there is the possibility to lower the lift by unlocking the ratchets manually.



The emergency lowering must only be performed by persons instructed to use the lift. Please refer to the regulation "Lowering".

Emergency lowering

- In case the ratchets are engaged turn operating switch to position " ", lift it a little bit until the ratchets are unlocked.
- Let go of operating switch and lock it in position "O"
- Take off coverings from ratchets and look which of the ratchet-ropes is torn.
- Pull back the relevant ratchet and lay a suitable support between ratchet-strip and ratchet or fix the pulled back ratchet with the help of a wire to avoid reengaging of the ratchet-tooth in the ratchet-strip. This measure is to do at this ratchet where the ratchet-rope is torn.
- Lower vehicle to lowest position (as described in chapter "operating instructions"). Refer to the regulations "Lowering"
- Take off support or wire from ratchets that they can engage again.



To guarantee the safe running of the lift the supports must be removed from the ratchet to bring the ratchet in its normal function

- After finishing with emergency lowering reinstall coverings.
- When the lift is in lowest position, slew carrying arms inside and drive vehicle out of the lift



After finishing with emergency lowering the lift must shut down until the defective ratchet has been replaced.

Torn rope

In case the safety-rope is torn the height limit switch and the switch off strip under the traverse is without function. The lift must shut down until the defective rope has been replaced. The new safety-rope must be installed as described in the following instruction.

- Disconnect power supply (disconnect feed line)
- Hang up safety-rope at topside (see pic. 5) and pull it through the empty rope guidance tube
- Hang up safety-rope in boring of the flat rolled steel (backside at operating switch). Turn operating switch to position " " and adjust length of the rope that the rope is stretched not too much.



Stretching of the safety-rope: a small activation of the switch-rod or of the switch-off strip must pull the operating switch to position "0".

- Connect power supply

In case the safety-rope is not torn, only slack, the rope must only be adjusted again after disconnecting the lift from power supply

7. Maintenance

A regular service has to be performed every three months by the lift's operator according to the following schedule. If the lift is in continuous operation or dirty environment, the maintenance rate has to be increased.

During daily operation the lift has to be watched carefully for its correct function. In case of any malfunction or leakage the technical service has to be informed.

Maintenance schedule for the lift

- Clean and grease all moving parts (pull-outs of the carrying arms, rollers of the lifting carriage guidances, hinge bolts of carrying arms)
- Check rubber supports of pads. in case they are worn change them.
- control ratchets: easy and smooth latching, lubricate striking surfaces
- check level of hydraulic oil
- Check the ropes.

The hydraulic oil has to be changed at least once a year. To change the oil lower the lift into its lowest position. Empty the tank and replace the oil, approximately 8 litres are needed. A high quality hydraulic oil is recommended, its viscosity should be 32 cst.

8. Security check

The security check is necessary to guarantee the safety of the lift during use. It has to be performed in the following cases:

1. Before the initial operation, after the first installation.
Use the form "First security check".
2. In regular intervals after the initial operation, at least annually.
Use the form "Regular security check".
3. Every time the construction of that particular lift has been changed.
Use the form "Extraordinary security check".

 ***The first and regular security checks must be performed by a competent. It is recommended to service the lift at this occasion.***

 ***After the construction of the lift has been changed (changing the lifting height or capacity for example) and after serious maintenance works (welding on carrying parts) an extraordinary security check must be performed by an expert.***

This manual contains form with a schedule for the security checks. Please use the adequate form for the security checks. The form should remain in this manual after they have been filled out.

9. Installation and Initiation

Installation of the lift

Regulations for the installation

- The installation of the lift is performed by trained technicians of the manufacturer or its distribution partner. If the operator can provide trained mechanics, he can install the lift by himself. The installation has to be done according to this regulation.
- The standard lift must not be installed in hazardous locations or washing areas.
- Installing the lift you need at least a reinforcement of 3,5 cm²/m Fe, quality B 25 (DIN 1045) in both directions at the upper and lower side of the plate. The thickness of the carrying concrete should be at least 200 mm. In case of other foundation or ground conditions a foundation according to foundation plan (refer to foundation plan) has to be provided: An even installation place has to be provided. The foundations must be based in a frost resistance depth, both outside and indoors, where you must reckon with frost
- An electric supply (observe the power supply of your state) has to be provided. The supply must be protected by customers (fuses). The electrical connection is located in command unit.
- All cable ducts have to be equipped with protective coverings to prevent accidents.

Erection and doweling of the lift

- Install the lift according to the data sheet and the foundation plan and line it up.
- Put both synchronizing ropes over the rolls at the top and insert them from the upper side in column. The ropes must not be crossed!
- Connect hydraulic hose between the two columns. Don't fix connection at opposite side too tight and don't fasten the connection. Be sure that hydraulic hose doesn't hinder the course of the synchronizing ropes.
- Put traverse topside on columns and fix it with enclosed cylinder screws and washers
- Connect oil-return line (synthetic material) at both columns (see pic. 4)
- Check position of the lift
- Bore holes to fix the dowels through the borings of the base plates. Clean holes with pressure air. Put in safety dowels with washers in borings. The manufacturer demands LIEBIG safety dowels type B 20 or equal dowels of another manufacturer. Before doweling check concrete floor with quality B 25 if the concrete floor goes to the top edge of the floor. In this case the dowels have to be chosen according to picture 2. If the ground is covered with floor tiles, the dowels have to be chosen

according to picture 3.

- Check line-up of the columns and look if they are vertical. If they aren't vertical correct with suitable bases.
- Tighten the Liebig-dowels with a dynamometric key (M = 80 Nm).

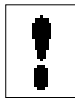

Each Liebig-dowels must be tightened with a torque of 80 Nm. The normal function of the lift cannot be guaranteed (Liebig = german dowel manufacturer).

- Connect power supply. The cable entry is at topside of operating column (standard version).
- Fill oil-tank with oil: viscosity 32 cst, hold-up: approximately 8 litre.
- pull ratchet back and lay a suitable support between ratchet strip and ratchet or fix theratchet, which is pulled back with a wire, to avoid engaging of the ratchet tooth in ratchet strip.
- Turn operating switch to position " " : Only one side of the lift is lifted. Lift the lift until oil comes out of the loosen threaded joint at topside of opposite column.
- Fasten threaded joint at top of opposite side.
- Load this carriage which has got a higher position (stand on it) and turn simultaneously operating switch to position " ". Only that carriage without load is lifted. That carriage must be lifted until the carriage at the operating side is 10 cm higher than the carriage at the opposite side.
- Dismount pulley at lower side in column (opposite side) by loosening the circlip. Lay loosen synchronizing rope from topside round the pulley and remount pulley with rope.



Secure pulley with washer and circlip while installing it.

- Insert synchronizing rope from lower side in ratchet strip which is fixed at lower side of carriage. Insert thread bolt at end of the rope through bore-hole which is located at hang up of the rope topside at ratchet strip.
- Screw self-locking nut approximately 4 turns on thread bolt to fix the rope safely at carriage.
- Load carriage of operating side (stand on it) and turn operating switch to position " ". Only the opposite side of the lift is lifted.
- Lift opposite side until carriage of operating side is lifted.
- Mount second rope in operating column as well.
- Fasten self-locking nuts at upper side in both carriages regularly until both ropes are tightened lightly. If the thread at upper side of carriage is too short, the self-locking nut at the other side carriage (lower side) must be fastened accordingly.

- Lower automotive lift to lowest position and lift it afterwards 500 - 600 mm. Both ropes must be tightened lightly. In any other case the self-locking nuts at the upper side of both carriages must be adjusted again.



Pay attention that each of the two ropes is tightened regularly and that it is not too slack, otherwise exact synchronization can not be guaranteed.



Pay attention that the ropes are not too tight, otherwise there is the possibility that the lift jerks, or that the lift is too slow while lowering



The ropes don't carry load. They must regulate an exact synchronization of the lift.

- Install carrying arms (refer to data sheet Power-Lift), lubricate bolts and secure them with enclosed circlips at both ends.



The bolts of the carrying arms must be secured at both ends, otherwise a safe connection between carriage and carrying arm can not be guaranteed.

- Deaerating the lift: lower the lift to lowest position. Loosen thread joint at lower side of cylinder which must be deaerated. Lift the lift until oil comes out of the thread joint. Now close the thread joint and fasten it.



In case the lift jerks while lowering there are two possibilities: the synchronizing ropes are too tight or oil is in oil circulation (deaerate according to instruction ahead)

- Loosen ratchet (now the tooth of the ratchet can engage in ratchet strip again)
- Hang up long ratchet-rope with end nipple in ratchet at column of opposite side. Take free end of the rope through rope-guidance tube to topside and afterwards take it through the rope-guidance tubes at traverse and at column of operating side to lower side again (see pic. 5).
- Mount thimble at end of the rope.
- Hang up ratchet-ropes with accompanying spring in operating lever "lowering"; operating lever is in initial position.
- The short ratchet-rope with end-nipple is already preassembled.
- Installing of the ratchet-ropes: Both ratchets mustn't be engaged when operating lever is completely pulled. The difference between backside of the ratchet and column should be approximately 60 mm (refer to pic. 6).
- For adjusting it might be necessary to loose one ratchet-rope and to stretch the other one to guarantee same position of both ratchets.



The ratchets must be free and their function must be guaranteed in any case.

 *Pay attention, that the "switch-off covering" is smooth and that the lift is switched off when the covering is pressed up. This covering is for switching off the lift while lifting the lift the same time a vehicle drives against it from upper side.*

- Lift and lower the lift with vehicle several times, tighten dowels a second time (M = 80 Nm).

Initiation

 *Before the initiation a security check must be performed. Therefore use form: First security check.*

If the lift is installed by a competent, he will perform this security check. If the operator installs the lift by himself, he has to instruct a competent to perform the security check.

The competent confirms the faultless function of the lift in the installation record and the form for the security check and allows the lift to be used.

 *Please send the filled installation record to the manufacturer after installation.*

Changing of the installation place

If the place of installation shall be changed, the new place has to be prepared according to the regulations of the first installation. The changing should be performed in accordance with the following points:

- lift carriage to medium height
- disconnect operating switch
- Take away current supply from lift
- Dismount carrying arms (remove circlips from carrying arm bolts, pull out carrying arm bolts and take off carrying arm)
- Loosen long ratchet-rope
- Separate hydraulic connections between columns
- Dismount traverse support between the columns
- Empty oil-tank
- loosen dowels between base plate and floor and take off columns
- Transport lift to new installation place
- Install lift in accordance with chapter "Installation and Initiation" of the lift.



Use new dowels, The used dowels cannot be used any more.



A security check must be performed before reinitiation by a competent. Use form "Regular security check".

pic. 2: choice of dowel lengths (without floor pavement or tile surface)

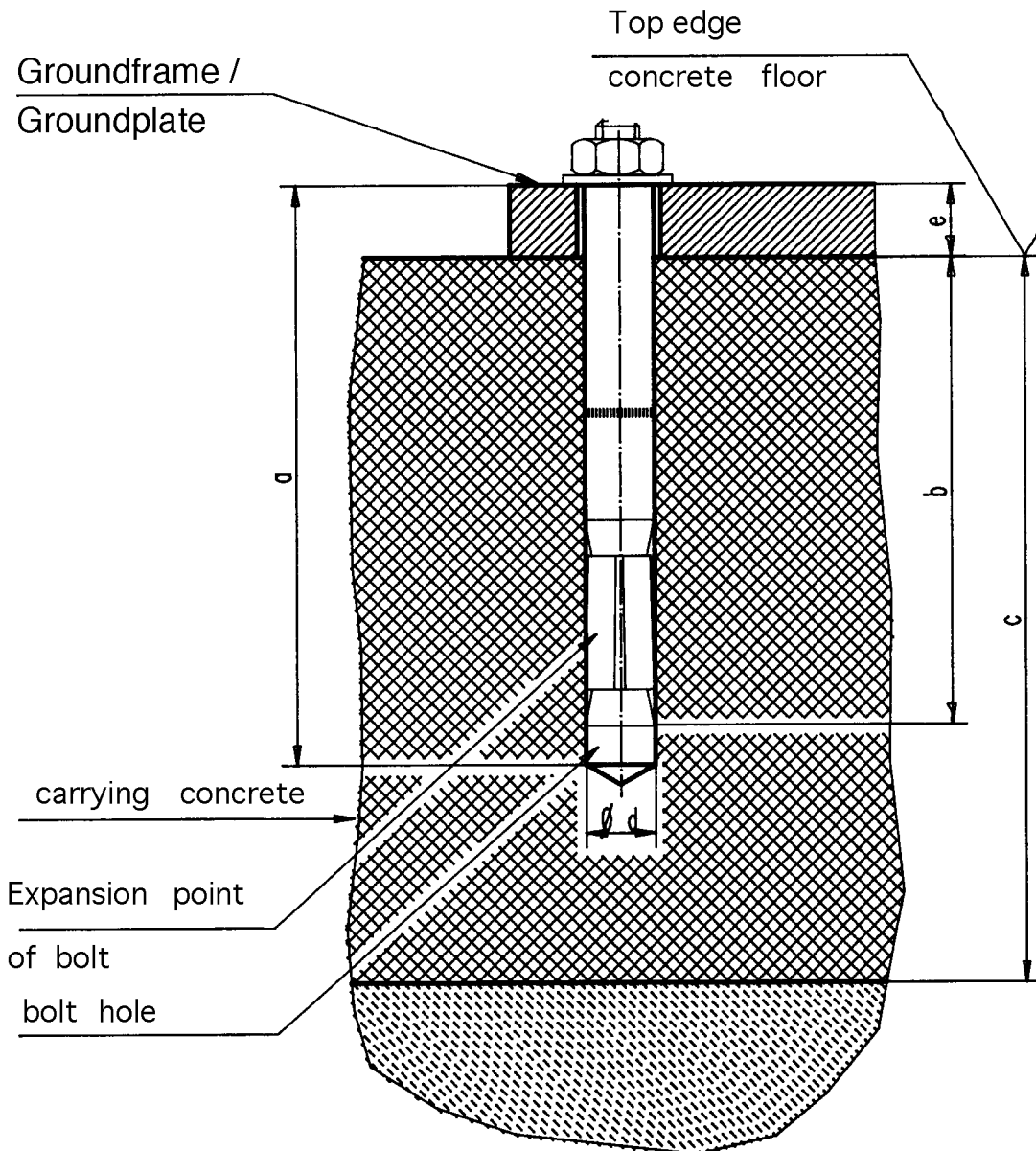

table to picture 5:

Liebig-safety dowels

type of dowel		B20/175
Drilling depth	a	225
min. anchorage depth	b	170
thickness of concrete	c	260
diameter of bor	d	20
thickness of the Lift-piece	e	0-65

You can use equivalent dowels from another manufacturer with licence, but observe their regulations.

pic. 3: Choice of dowel lengths (with floor pavement or tile surface)

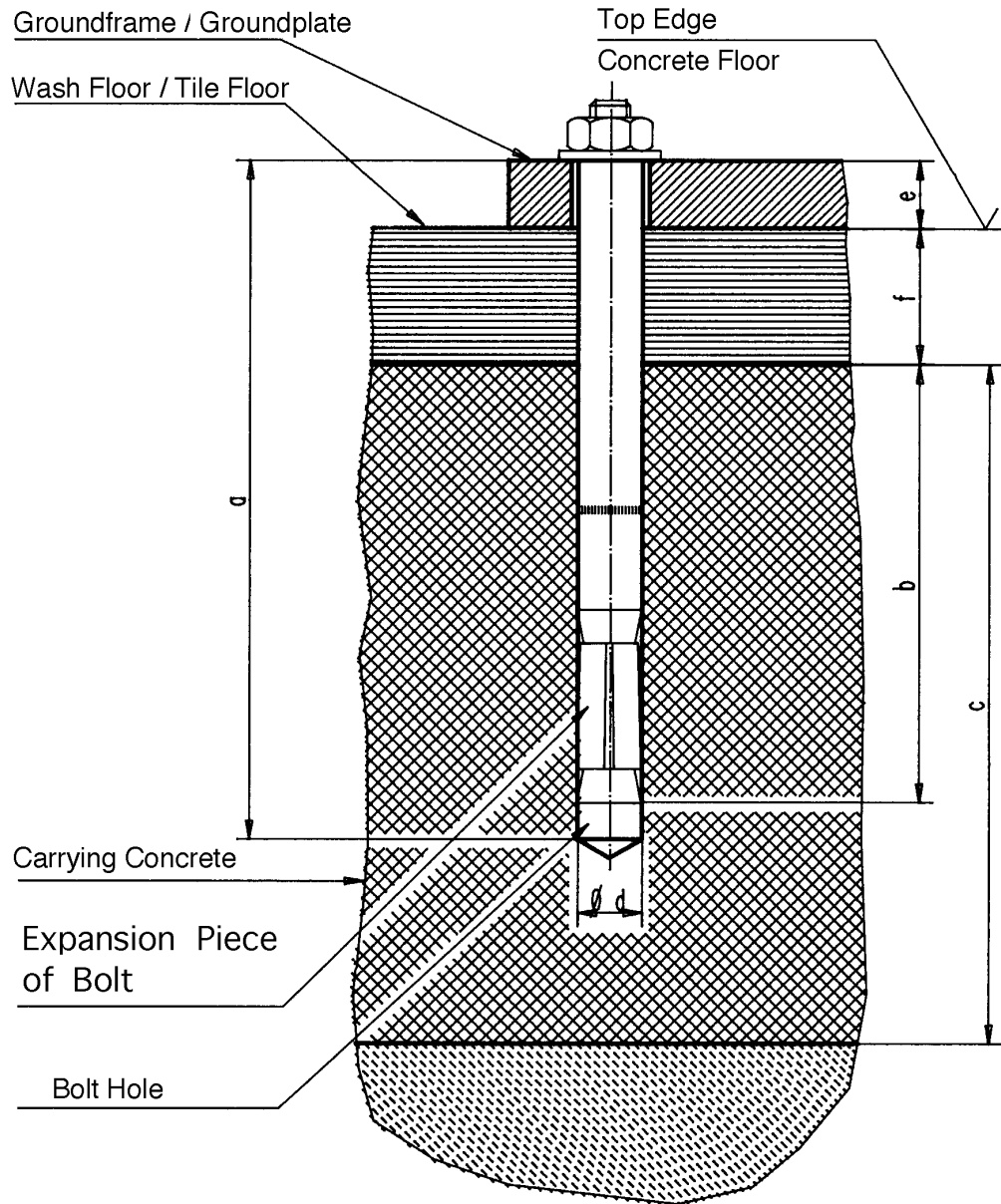
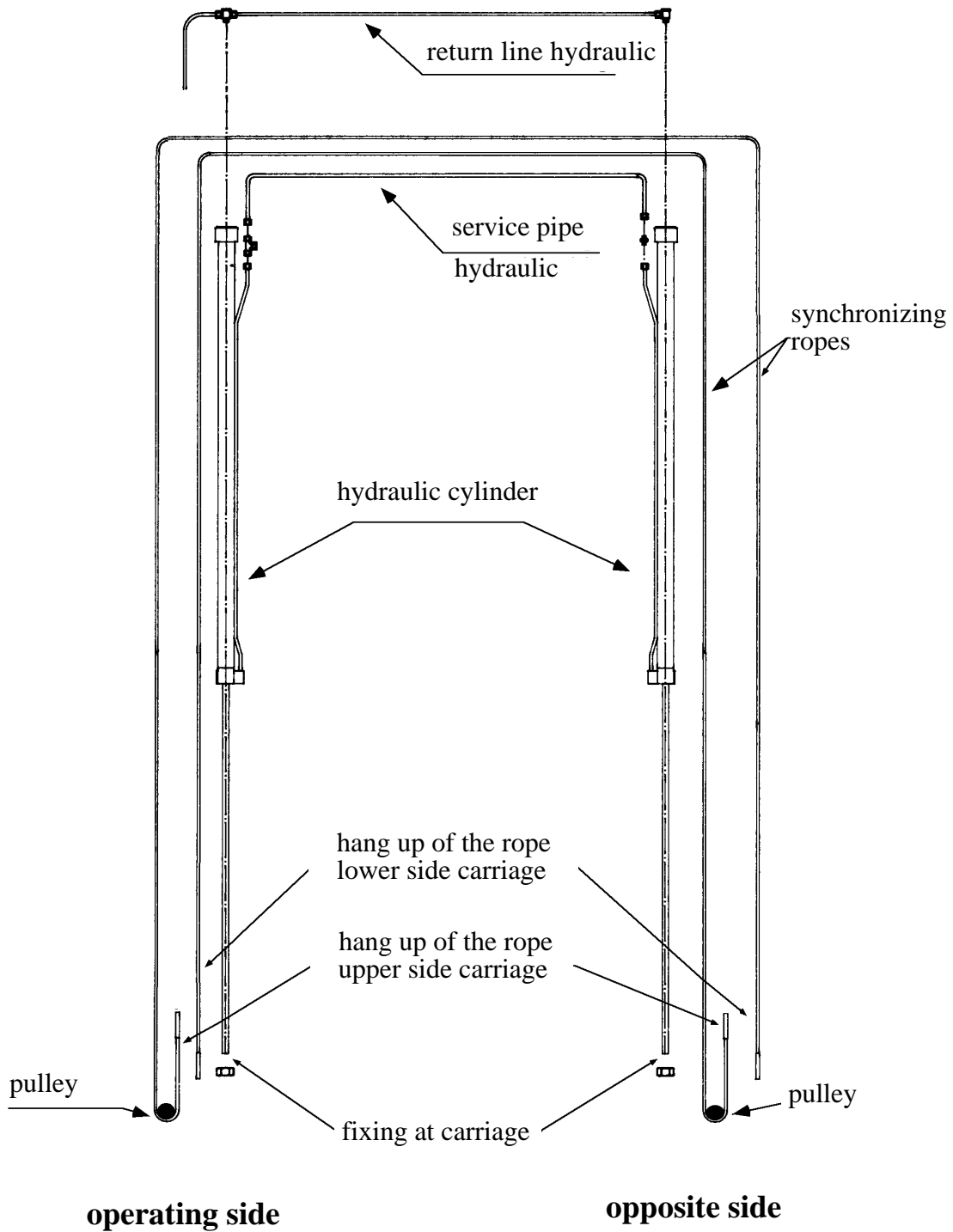

table to picture 3:

type of dowel		B20/175	B20/225
Drilling depth	a	225	275
min. anchorage depth	b	170	170
thickness of concrete	c	260	260
diameter of bor	d	20	20
thickness of the Lift-piece + thickness of floor pavement	e+f	0-65	65-115

You can use equivalent dowels from another manufacturer with licence, but observe their regulations.

pic. 4: course of the hoses



pic. 5: ratchet-rope

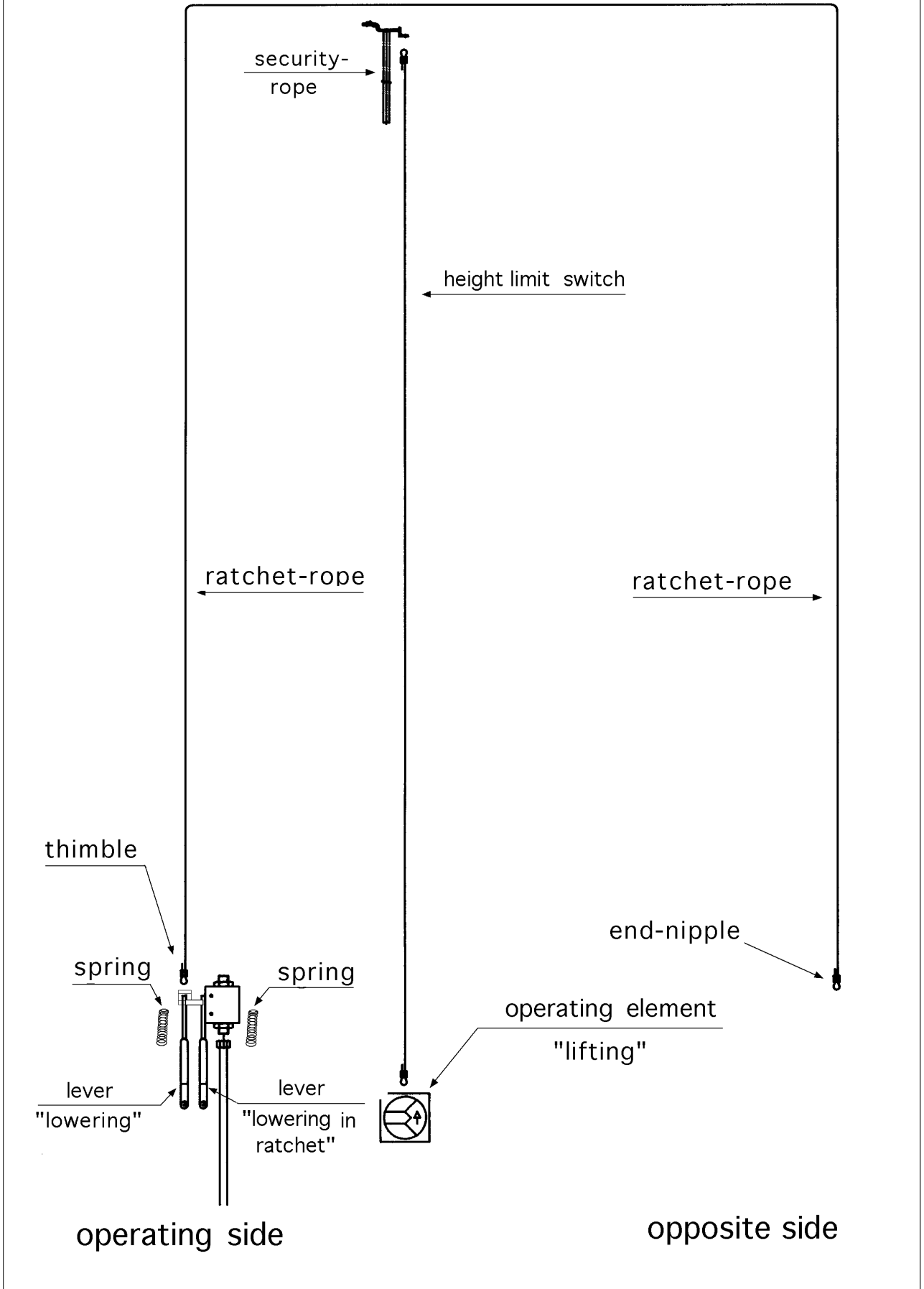

pic. 6: ratchet

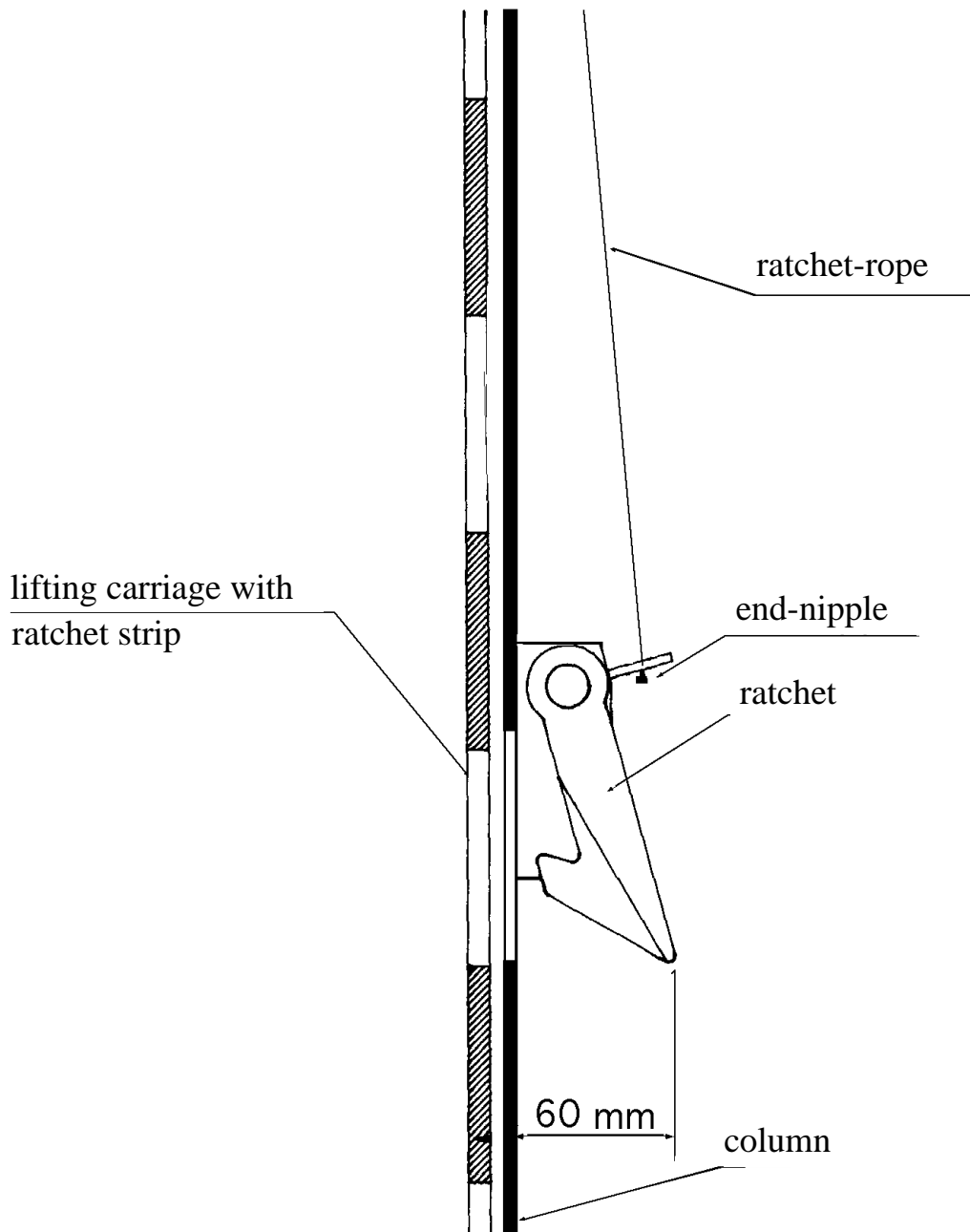

First security check before installation



to fill in and to leave in this document

kind of check	all right	defect lacking	verification	Remark
Type plate	<input type="checkbox"/>	<input type="checkbox"/>	<input type="checkbox"/>
Short operating instructions.....	<input type="checkbox"/>	<input type="checkbox"/>	<input type="checkbox"/>
Warning designation	<input type="checkbox"/>	<input type="checkbox"/>	<input type="checkbox"/>
Detailed operating instructions.....	<input type="checkbox"/>	<input type="checkbox"/>	<input type="checkbox"/>
Designation Lifting/Lowering	<input type="checkbox"/>	<input type="checkbox"/>	<input type="checkbox"/>
Operating switch lockable.....	<input type="checkbox"/>	<input type="checkbox"/>	<input type="checkbox"/>
Function limit switches	<input type="checkbox"/>	<input type="checkbox"/>	<input type="checkbox"/>
Safety device hinge bolt	<input type="checkbox"/>	<input type="checkbox"/>	<input type="checkbox"/>
Security of pads	<input type="checkbox"/>	<input type="checkbox"/>	<input type="checkbox"/>
Condition rubber support of pads ..	<input type="checkbox"/>	<input type="checkbox"/>	<input type="checkbox"/>
Function fixing of carrying arms ..	<input type="checkbox"/>	<input type="checkbox"/>	<input type="checkbox"/>
Construction (deformation, cracking)	<input type="checkbox"/>	<input type="checkbox"/>	<input type="checkbox"/>
Fixed seat of the carrying screws	<input type="checkbox"/>	<input type="checkbox"/>	<input type="checkbox"/>
Function, condition ratchet-system.....	<input type="checkbox"/>	<input type="checkbox"/>	<input type="checkbox"/>
guidance of carriage in column.....	<input type="checkbox"/>	<input type="checkbox"/>	<input type="checkbox"/>
Condition synchronizing rope, hang-up.....	<input type="checkbox"/>	<input type="checkbox"/>	<input type="checkbox"/>
Condition pulleys.....	<input type="checkbox"/>	<input type="checkbox"/>	<input type="checkbox"/>
Condition coverings	<input type="checkbox"/>	<input type="checkbox"/>	<input type="checkbox"/>
Condition hydraulic hoses.....	<input type="checkbox"/>	<input type="checkbox"/>	<input type="checkbox"/>
Oil level gage.....	<input type="checkbox"/>	<input type="checkbox"/>	<input type="checkbox"/>
Closeness of hydraulic system.....	<input type="checkbox"/>	<input type="checkbox"/>	<input type="checkbox"/>
surface of piston-rod	<input type="checkbox"/>	<input type="checkbox"/>	<input type="checkbox"/>
Condition electrical wires, earth contactor...	<input type="checkbox"/>	<input type="checkbox"/>	<input type="checkbox"/>
Test: lift with vehicle	<input type="checkbox"/>	<input type="checkbox"/>	<input type="checkbox"/>
Condition concrete floor (cracks)	<input type="checkbox"/>	<input type="checkbox"/>	<input type="checkbox"/>

(mark where applicable, in case of verification mark in addition to the first mark!)

security check carried out:

Name, address of the competent.....

Result of the Check:

- Initiation not permitted, verification necessary
- Initiation possible, repair failures until
- No failings, Initiation possible

Signature of the expert:.....

Signature of the operator:.....

If failures must be repaired

Failures repaired at:

Signature of the operator:.....

(Use another form for verification!)

Regular security check



to fill in and to leave in this document

kind of check	all right	defect lacking	verification	Remark
Type plate	<input type="checkbox"/>	<input type="checkbox"/>	<input type="checkbox"/>
Short operating instructions.....	<input type="checkbox"/>	<input type="checkbox"/>	<input type="checkbox"/>
Warning designation	<input type="checkbox"/>	<input type="checkbox"/>	<input type="checkbox"/>
Detailed operating instructions.....	<input type="checkbox"/>	<input type="checkbox"/>	<input type="checkbox"/>
Designation Lifting/Lowering	<input type="checkbox"/>	<input type="checkbox"/>	<input type="checkbox"/>
Operating switch lockable.....	<input type="checkbox"/>	<input type="checkbox"/>	<input type="checkbox"/>
Function limit switches	<input type="checkbox"/>	<input type="checkbox"/>	<input type="checkbox"/>
Safety device hinge bolt	<input type="checkbox"/>	<input type="checkbox"/>	<input type="checkbox"/>
Security of pads	<input type="checkbox"/>	<input type="checkbox"/>	<input type="checkbox"/>
Condition rubber support of pads	<input type="checkbox"/>	<input type="checkbox"/>	<input type="checkbox"/>
Function fixing of carrying arms	<input type="checkbox"/>	<input type="checkbox"/>	<input type="checkbox"/>
Construction (deformation, cracking)	<input type="checkbox"/>	<input type="checkbox"/>	<input type="checkbox"/>
Fixed seat of the carrying screws	<input type="checkbox"/>	<input type="checkbox"/>	<input type="checkbox"/>
Function, condition ratchet-system.....	<input type="checkbox"/>	<input type="checkbox"/>	<input type="checkbox"/>
guidance of carriage in column.....	<input type="checkbox"/>	<input type="checkbox"/>	<input type="checkbox"/>
Condition synchronizing rope, hang-up.....	<input type="checkbox"/>	<input type="checkbox"/>	<input type="checkbox"/>
Condition pulleys.....	<input type="checkbox"/>	<input type="checkbox"/>	<input type="checkbox"/>
Condition coverings	<input type="checkbox"/>	<input type="checkbox"/>	<input type="checkbox"/>
Condition hydraulic hoses.....	<input type="checkbox"/>	<input type="checkbox"/>	<input type="checkbox"/>
Oil level gage.....	<input type="checkbox"/>	<input type="checkbox"/>	<input type="checkbox"/>
Closeness of hydraulic system.....	<input type="checkbox"/>	<input type="checkbox"/>	<input type="checkbox"/>
surface of piston-rod	<input type="checkbox"/>	<input type="checkbox"/>	<input type="checkbox"/>
Condition electrical wires, earth contactor...	<input type="checkbox"/>	<input type="checkbox"/>	<input type="checkbox"/>
Test: lift with vehicle	<input type="checkbox"/>	<input type="checkbox"/>	<input type="checkbox"/>
Condition concrete floor (cracks)	<input type="checkbox"/>	<input type="checkbox"/>	<input type="checkbox"/>

(mark where applicable, in case of verification mark in addition to the first mark!)

security check carried out:

Name, address of the competent.....

Result of the Check:

Initiation not permitted, verification necessary

Initiation possible, repair failures until

No failings, Initiation possible

Signature of the expert:.....

Signature of the operator:.....

If failures must be repaired

Failures repaired at:

Signature of the operator:.....

(Use another form for verification!)

Extraordinary security check



to fill in and to leave in this document

kind of check	all right	defect lacking	verification	Remark
Type plate	<input type="checkbox"/>	<input type="checkbox"/>	<input type="checkbox"/>
Short operating instructions.....	<input type="checkbox"/>	<input type="checkbox"/>	<input type="checkbox"/>
Warning designation	<input type="checkbox"/>	<input type="checkbox"/>	<input type="checkbox"/>
Detailed operating instructions.....	<input type="checkbox"/>	<input type="checkbox"/>	<input type="checkbox"/>
Designation Lifting/Lowering	<input type="checkbox"/>	<input type="checkbox"/>	<input type="checkbox"/>
Operating switch lockable.....	<input type="checkbox"/>	<input type="checkbox"/>	<input type="checkbox"/>
Function limit switches	<input type="checkbox"/>	<input type="checkbox"/>	<input type="checkbox"/>
Safety device hinge bolt	<input type="checkbox"/>	<input type="checkbox"/>	<input type="checkbox"/>
Security of pads	<input type="checkbox"/>	<input type="checkbox"/>	<input type="checkbox"/>
Condition rubber support of pads	<input type="checkbox"/>	<input type="checkbox"/>	<input type="checkbox"/>
Function fixing of carrying arms	<input type="checkbox"/>	<input type="checkbox"/>	<input type="checkbox"/>
Construction (deformation, cracking)	<input type="checkbox"/>	<input type="checkbox"/>	<input type="checkbox"/>
Fixed seat of the carrying screws	<input type="checkbox"/>	<input type="checkbox"/>	<input type="checkbox"/>
Function, condition ratchet-system.....	<input type="checkbox"/>	<input type="checkbox"/>	<input type="checkbox"/>
guidance of carriage in column.....	<input type="checkbox"/>	<input type="checkbox"/>	<input type="checkbox"/>
Condition synchronizing rope, hang-up.....	<input type="checkbox"/>	<input type="checkbox"/>	<input type="checkbox"/>
Condition pulleys.....	<input type="checkbox"/>	<input type="checkbox"/>	<input type="checkbox"/>
Condition coverings	<input type="checkbox"/>	<input type="checkbox"/>	<input type="checkbox"/>
Condition hydraulic hoses.....	<input type="checkbox"/>	<input type="checkbox"/>	<input type="checkbox"/>
Oil level gage.....	<input type="checkbox"/>	<input type="checkbox"/>	<input type="checkbox"/>
Closeness of hydraulic system.....	<input type="checkbox"/>	<input type="checkbox"/>	<input type="checkbox"/>
surface of piston-rod	<input type="checkbox"/>	<input type="checkbox"/>	<input type="checkbox"/>
Condition electrical wires, earth contactor... ..	<input type="checkbox"/>	<input type="checkbox"/>	<input type="checkbox"/>
Test: lift with vehicle	<input type="checkbox"/>	<input type="checkbox"/>	<input type="checkbox"/>
Condition concrete floor (cracks)	<input type="checkbox"/>	<input type="checkbox"/>	<input type="checkbox"/>

(mark where applicable, in case of verification mark in addition to the first mark!)

security check carried out:

Name, address of the competent.....

Result of the Check:

Initiation not permitted, verification necessary

Initiation possible, repair failures until

No failings, Initiation possible

Signature of the expert:.....

Signature of the operator:.....

If failures must be repaired

Failures repaired at:

Signature of the operator:.....

(Use another form for verification!)

Spare parts list drawing: columns, coverings, cylinder, ropes

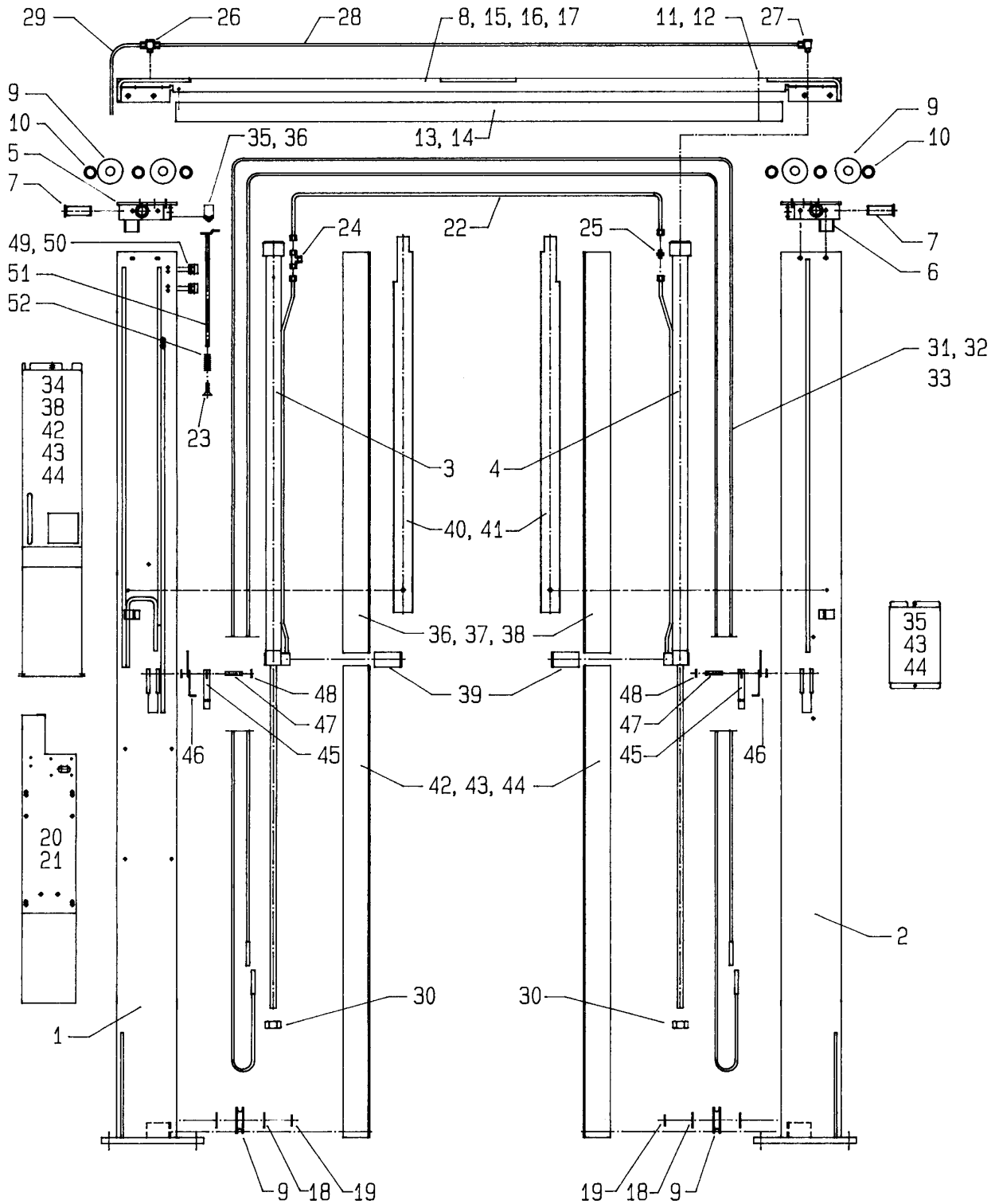

operating side

opposite side

Spare parts list drawing: columns, coverings, cylinder, ropes

Number	Description	Code
1	column operating side	235SPL05003
2	column opposite side	235SPL05039
3	hydraulic cylinder	232POW22003
4	hydraulic cylinder	232POW22002
5	head plate operating side	232POW25020
6	head plate opposite side	232POW25056
7	bolt of pulley	232POW05026
8	traverse	235SPL05074
9	pulley	232NSTL05063
10	distance bush	232NSTL05034D
11	cylinder screw	9Z912M10*110ZN
12	hexagon nut	9MU934M10ZN
13	switch off covering	232POW09016
14	pan-head screw	9F921M06*012ZN
15	hexagon head cap screw	9S933M10*020ZN
16	lock washer	9FR127M10ZN
17	hexagon head cap screw	9S933M10*016ZN
18	AS-washer	970022
19	Seeger circlip ring	9SR030*1.5
20	aggregate backside, welding piece	235SPL05092
21	countersunk screw	9S7991M08*16ZN
22	hydraulic tube	232POW01030
23	countersunk screw	9SE7991M08*12ZN
24	Male Stud branch Tee	980020
25	Male Stud coupling	980018
26	Male Stud branch Tee	960024
27	banjo elbow	960023
28	oil-return line	232POW01041
29	oil-return line	232POW01042
30	hexagon nut self-locking	9MU985M18*1.5ZN
31	set of control ropes	970405
32	hexagon nut self-locking	9MU985M12ZN
33	washer	9SC125M12ZN
34	covering	235SPL49024
35	covering of column opposite side	235SPL09020
36	covering of cylinder	235SPL09003
37	countersunk screw	9SE7991M05*12ZN
38	rosette	970010
39	cover band	232POW09006
40	cable cover	232POW09008

**Spare parts list****SPL 9000****Spare parts list drawing: columns, coverings, cylinder, ropes**

Number	Description	Code
41	hexagon nut	9MU934M06ZN
42	countersunk screw	9SE7991M05*08ZN
43	cylinder screw	9Z912M06*010ZN
44	lock washer	9FR7980M06ZN
45	ratchet	232SPL10003
46	leg spring	970251
47	bolt of bearing	232POW10008
48	Seeger circlip ring	9SR012*1
49	guidance	232POW10020
50	cylinder screw	9Z912M08*025ZN
51	switching-rod	232SPL10021
52	pressure spring	9DFD-187ZN

Spare parts list drawing: carriages, standard carrying arms

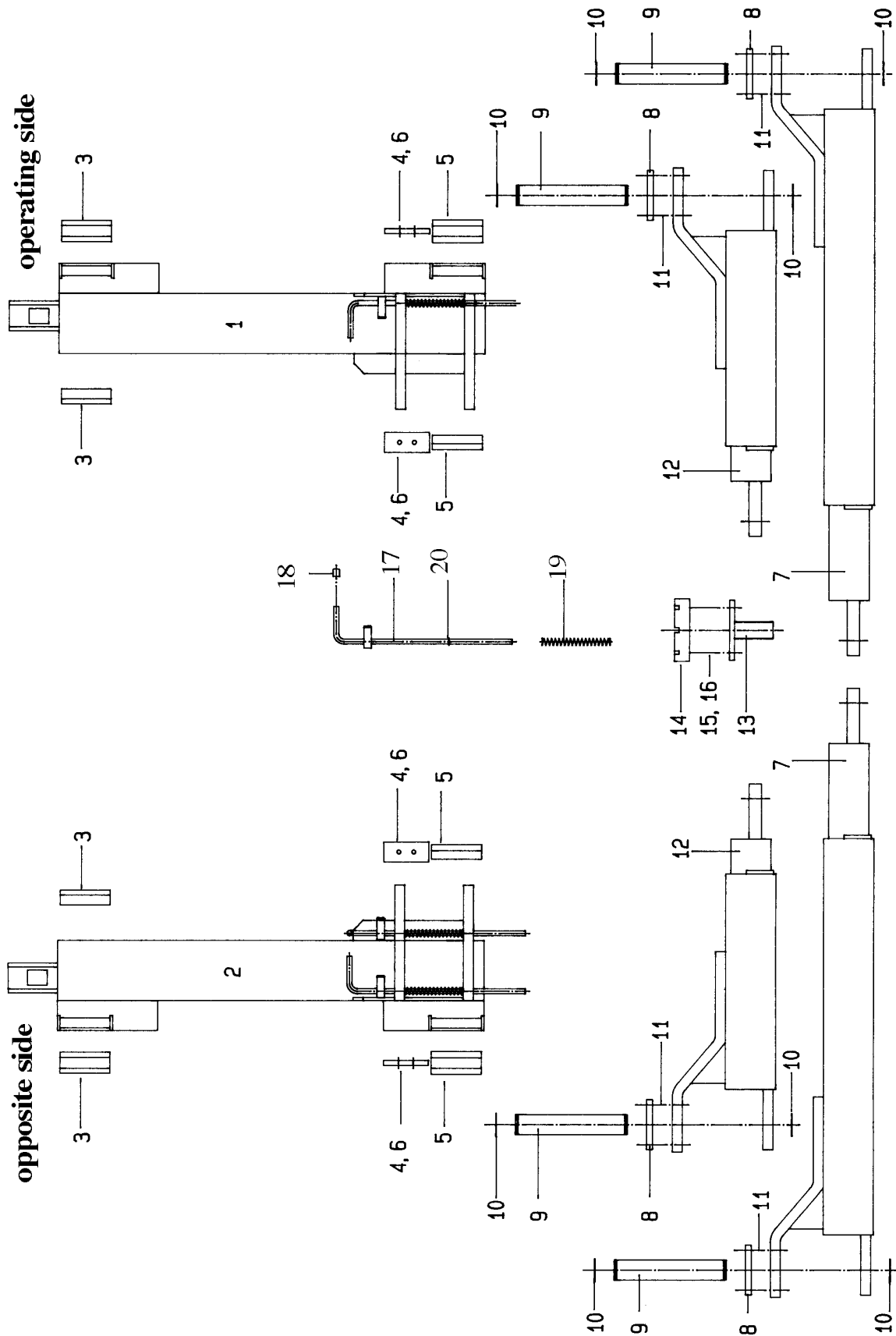

Spare parts list Power-Lift: carriage, carrying arms

Number	Description	Code
1	carriage, operating side	232POW06003
2	carriage, opposite side	232POW06039
3	sliding block topside	232POW06014
4	sliding block, lower side	232POW06015
5	sliding block bottom frontside	232POW06030
6	countersunk screw	9SE7991M06*20ZN
7	carrying arm (long)	232POW28003D
8	tooth lock washer	232NSTL08013
9	hinge bolt	232NSTL08016
10	shaft ring	970006
11	cylinder screw	9Z912M08*025ZN
12	carrying arm (short)	232POW28039
13	pad	232HEL08075
14	elastomer support	901103031
15	countersunk screw	9SE963M06*20ZN
16	hexagon nut	9MU934M06ZN
17	pull-handle	232NSTL08096
18	protecting cap	970008
19	compression spring	9DFD-222SLZN
20	heavy clamping sleeve	9SH1481DM03*16ZN

Spare parts list drawing: hydraulic-aggregate

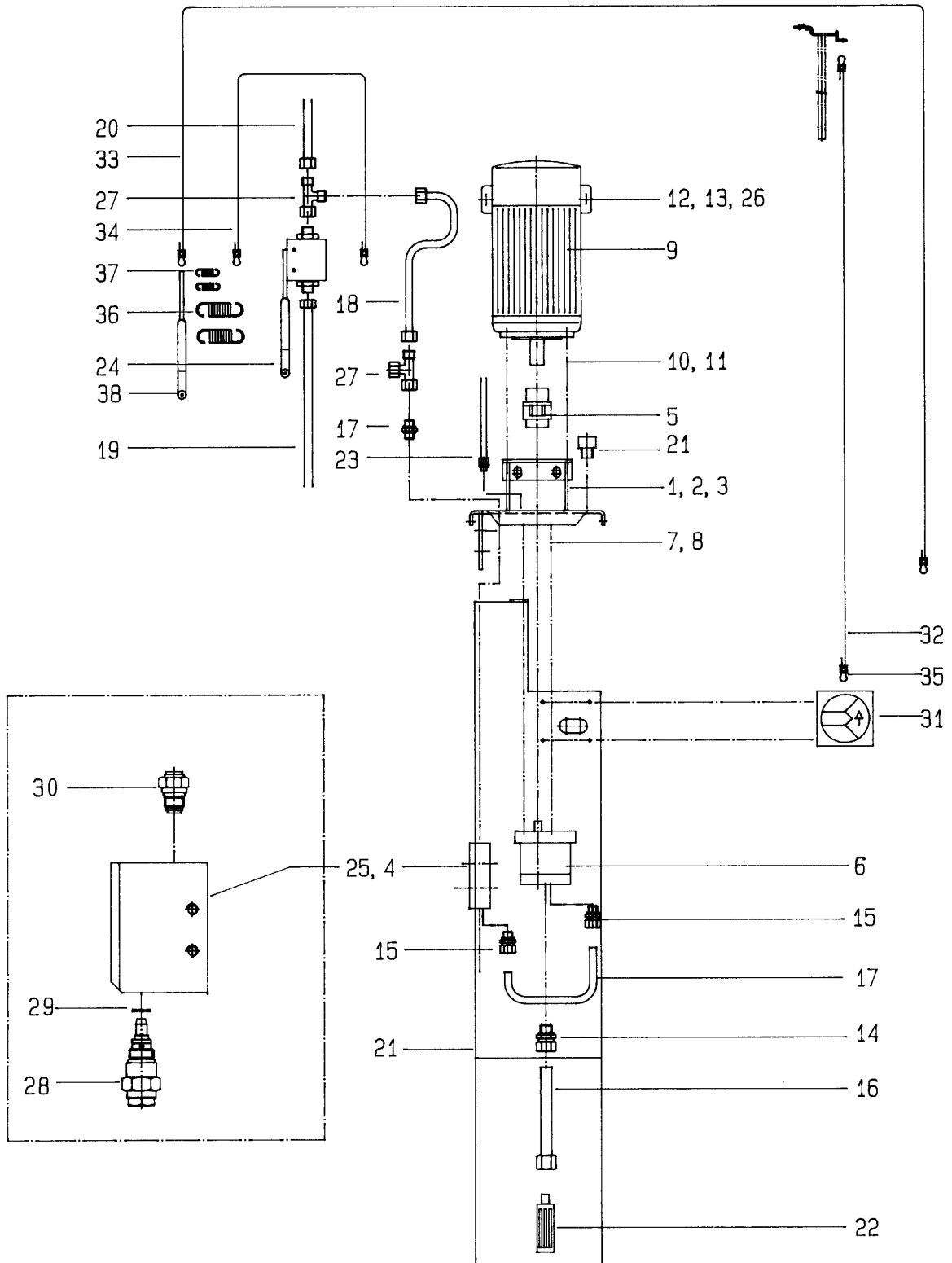

Spare parts list: hydraulic-aggregate

Number	Description	Code
1	pump carrier	232POW21003
2	cylinder screw	9Z912M08*012ZN
3	lock washer	9FR7980M08ZN
4	countersunk screw	9SE7991M08*16
5	coupling	970290
6	pump	980243
7	cylinder screws	9Z912M08*085ZN
8	lock washer	9FR7980M08ZN
9	motor 3.0 KW (standard version)	990303
10	cylinder screw	9Z912M06*016ZN
11	lock washer	9FR7980M06ZN
12	cylinder screw	9Z912M08*016ZN
13	washer	9SC125M08ZN
14	Male Stud coupling	980135
15	Male Stud coupling	980014
16	suction pipe	232POW01028
17	hydraulic tube (pump to hydraulic block)	232POW01029
18	hydraulic tube (hydraulic block to T-piece)	232SPL01050
19	hydraulic tube(ball valve to hydraulic block)	232SPL01055
20	hydraulic tube (T-piece to cylinder)	232SPL01034
21	deerate screw	980006
22	oil-filter	980201
23	Male Stud coupling	960025
24	ball valve	980512
	operating lever	235SPL22033
25	hydraulic block complete	232SPL22037
26	hexagon nut	9MU934M08ZN
27	Adjustable Male Stud Run Tees	980071
28	pressure relief valve, complete	232NSTL02082
29	USIT-ring	980240
30	holding valve	980480
31	operating (reversing) switch (small)	990391
32	steel cord for operating switch	235SPL10014
33	steel cord for unlocking the ratchet	235SPL10012
34	steel cord for unlocking the ratchet	235SPL10013
35	luster terminal	990037
36	tension spring	9ZFZ-141ZN
37	tension spring	9ZFZ-092ZN
38	ratchet-lever	235SPL02020

